

INSTALLATION OF FASTENERS FOR TAILGATE LATCH HANDLE MOUNTING PLATE

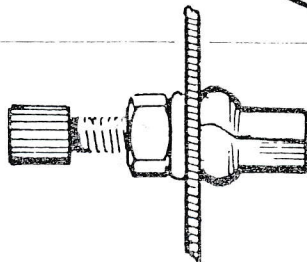
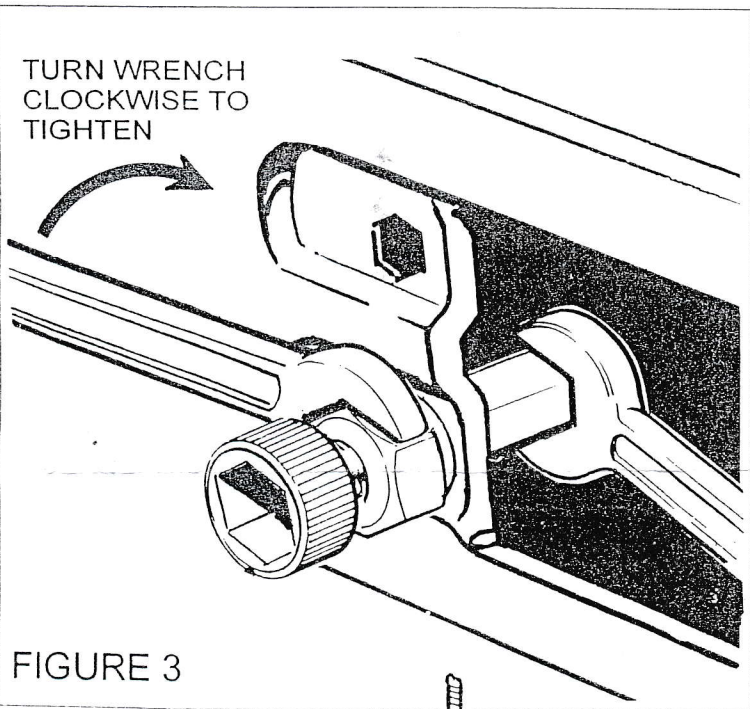
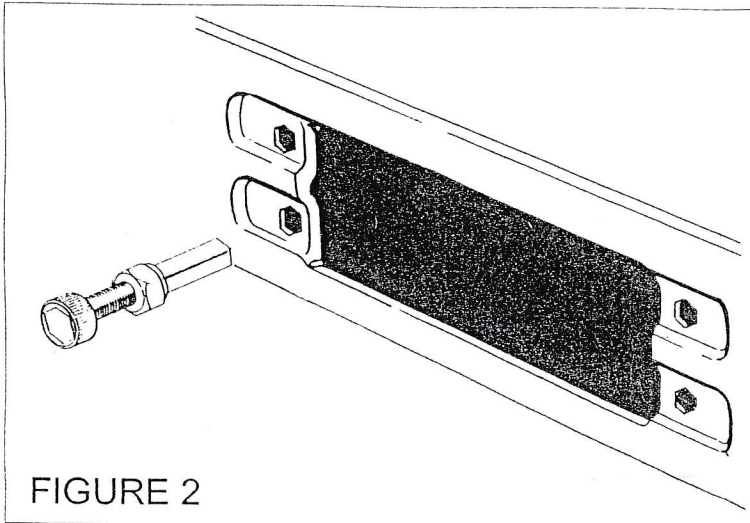
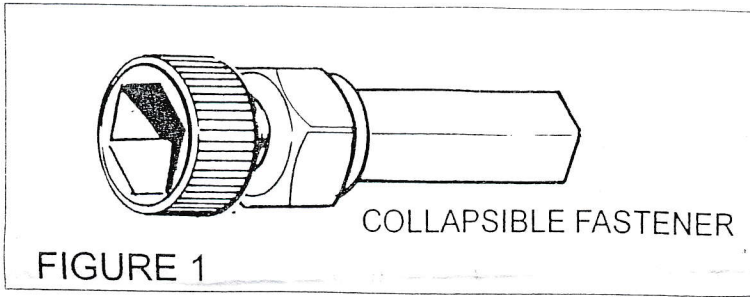

1. Thread the nut, then the collapsible fastener onto the allen head bolt as shown in figure 1.

NOTE: The bolt should be threaded into the collapsible fastener so that the bolt end becomes flush with the fastener end.

2. Insert the fastener assembly (shown in figure 2) into one of the 4 holes located in the center of the tailgate, where the latch is located.

3. Using a 5/16" wrench, hold steady by the end, the collapsible fitting inside the tailgate while turning the nut on the allen bolt clockwise, with a 7/16" wrench effectively tightening the nut. See figure 3.

4. As the nut is turned, the fastener begins to draw within itself causing it to flare out. Continue tightening the nut until the fastener is secured to the tailgate. DO NOT OVER TIGHTEN. The desired shape of the installed fitting is shown in figure 4.

5. After the fastener is secured, loosen the 1/2" nut on the allen bolt, then using the appropriate allen wrench, remove the bolt from the fastener.

6. To install the remaining 3 fasteners, repeat steps 1 through 5.



DENNIS CARPENTER FORD REPRODUCTIONS

P.O. BOX 26398

CHARLOTTE, NC. 28221-6398

704-786-8139